

## Purpose

**Surfer** is a compact hand-held instrument for measuring the speed of a pulse of ultrasonic longitudinal stress waves propagating within the near surface concrete; that is, it measures the ultrasonic pulse velocity (UPV). The instrument incorporates two dry-point-contact (DPC) transducers that are brought into contact with the surface of the test object. Thus ultrasonic pulse velocity can be measured without having access to opposite sides of the test object. **Surfer** can be used for the following applications:

- Assessment of concrete uniformity
- Estimation of the extent and severity of deterioration of near-surface concrete
- Evaluate flexural strength of stone panels using correlations
- Evaluation of damage to test specimens during durability testing (freezing and thawing, sulfate attack, alkali-silica reaction)
- Estimation of depth of surface-opening cracks
- Estimation of early-age strength development (with project/mixture specific correlation)



## Principle

**Surfer** is based on measuring the time it takes for a pulse of longitudinal stress waves (P-waves) to travel from one transducer to another on the same surface. Because point transducers are used, the wave pulse travels away from the transmitting transducer along a spherical wavefront. When the wavefront arrives at the receiving transducer, a signal is generated. The instrument measures the pulse transit time from transmitter to receiver and computes the pulse velocity using the known distance between transducers. The transducers are designed to work without a coupling material (grease or gel). In contrast with traditional pulse velocity instruments, which are based on through transmission, **Surfer** measures the wave speed in the near-surface concrete. Thus it is not necessary to have access to opposite sides of the test object. Because there is no cabling, no coupling fluid, and no need to measure the distance between transducers, measurements can be made rapidly within 2 to 3 seconds.

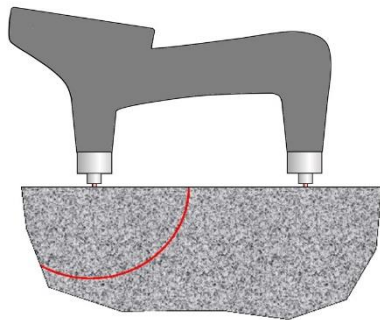

## Method of Operation

There are two main modes of operation:

- Measurement of transit time and pulse velocity
- Measurement of depths of surface-opening cracks

Before making transit time measurements, the menu system and keypad are used to set up the instrument. The instrument includes a liquid crystal display (LCD) that can be set up to display transit time or pulse velocity. After the set-up parameters have been entered, the transducers are pressed firmly against the concrete surface. The device will self-activate and begin taking measurements. The transducers need to be perpendicular to the surface and a steady pressure needs to be maintained to obtain accurate and consistent measurements.

Before making measurements in reinforced concrete, a reinforcement locator (**Conquest™ GPR** for instance) should be used locate the reinforcing bars. Orient the **Surfer** so that the effects of the reinforcement are minimized. The above sketch shows acceptable and unacceptable positioning of the **Surfer**. If the device is aligned close to

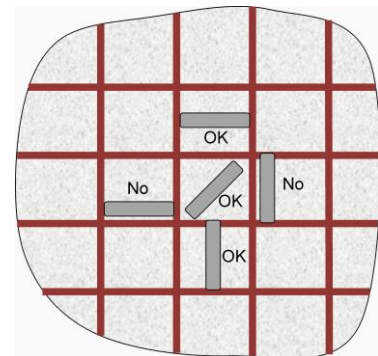

and parallel to the reinforcement, the stress pulse will refract into the reinforcement and a short transit time will be measured.

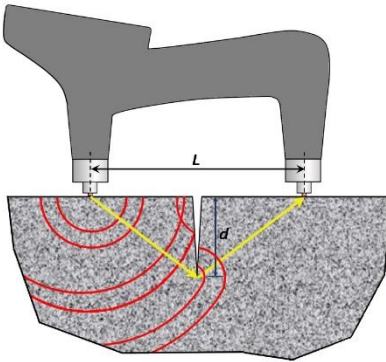

**Surfer** can also be used to measure the depths of surface-opening cracks. When the stress pulse reaches the tip of a surface-opening crack, the pulse is diffracted by the crack tip. The diffracted pulse travels away from the crack tip and is detected by the receiver. Because the crack increases the length of the travel path from transmitter to receiver, the transmit time will be greater than if no crack were present. Crack depth is determined by making two transit time measurements. The first one is made with the transducers aligned parallel to the crack, and the second one is made with the transducers perpendicular to the crack. For the second measurement, the crack should be at the midpoint between the transducers. **Surfer** uses these transit times and the distance between the transducers to calculate the crack depth:

$$d = \frac{L}{2} \sqrt{\left(\frac{t_c}{t_p}\right)^2 - 1}$$

Where  $L$  is the distance between the transducers,  $t_p$  is the transit time measured with the transducers parallel to the crack, and  $t_c$  is the transit time with transducers perpendicular to the crack. The LCD will indicate the two transit times and the calculated crack depth. The following summarizes the process:



Measure transit time ( $t_p$ ) parallel to crack



Measure transit time ( $t_c$ ) across crack

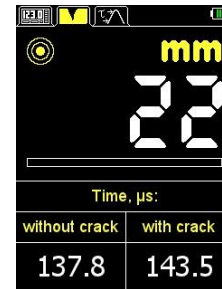

Display of transit times and crack depth

## Estimating In-place Strength

To use **Surfer** to estimate early-age strength development of concrete, a relationship needs to be established between concrete strength and pulse velocity. Such a relationship can be established by making pulse velocity measurements on standard strength test specimens and then measuring their compressive strength. The resulting data can be used to develop a regression equation to represent the relationship between concrete strength and pulse velocity. Refer to ACI 228.1R (In-Place Methods to Estimate Concrete Strength) for guidance on developing and using the strength relationship. The relationship that is developed is applicable only to that specific concrete mixture.



## Elastic Modulus Degradation

Because the modulus of elasticity is proportional to the square of the pulse velocity, **Surfer** can be used as an alternative to resonant frequency testing to monitor deterioration of specimens used in standard durability tests, such as freezing and thawing. In such tests, the decrease in the dynamic modulus of elasticity is used as an indicator of deterioration. The elastic modulus ratio is equal to the square of the pulse velocity ratio:

$$\frac{E_n}{E_i} = \left( \frac{V_n}{V_i} \right)^2$$

Where  $V_i$  and  $E_i$  are the initial values of pulse velocity and modulus of elasticity; and  $V_n$  and  $E_n$  are the values of pulse velocity and modulus of elasticity after exposure to the test conditions.

## Surfer Specifications

- Dry point contact, longitudinal-wave transducers with ceramic wearing tips.
- Distance between transducers: 150 mm.
- 50 kHz center frequency.
- Nominal voltage: 3.3 V.
- Rechargeable battery with 16 hours life.
- LCD screen.
- Data transfer to computer via USB.
- Transit time range: 12.5 to 150  $\mu$ s.
- Transit time (t) measurement accuracy:  $\pm (0.01 \cdot t + 0.1)$   $\mu$ s.
- Crack depth measurement range: 10 to 60 mm.
- Pulse repetition frequency: 2 to 25 Hz.
- Automatic Gain Control (AGC) function.
- Storage capacity: 50,000 results.
- Metric and inch-pound units.
- Instrument's weight: 450 g.
- Instrument's dimensions: 235 x 155 x 65 mm.
- Operating conditions: Temperature: -20 to 50  $^{\circ}$ C, RH  $\leq$  95 %.

## Surfer (SURF-1000) Ordering Numbers

Item	Order #
Hand-held unit with carrying case	SURF-1001
Plexiglas plate for operational check	SURF-1002
Charger and USB cable for connection to PC	SURF-1003
User manual	SURF-1005

