



Chapman and Hall  
London · New York · Tokyo · Melbourne · Madras  
Co-published in the United States with  
Van Nostrand Reinhold, Inc., New York  
ISBN 0-442-31389-6 (USA only)

# Testing during Concrete Construction

Testing during Concrete Construction  
Edited by H. W. Reinhardt  
RILEM Proceedings 11

The usual way of monitoring concrete, by measuring the strength of test specimens after 28 days, gives no information about the concrete in the structure, such as the materials used, the compaction or curing of the concrete or the cover to the reinforcement.

Techniques are being developed or are already available which can be used during construction to measure the quality of the fresh concrete (such as the mix proportions or compaction), the early age properties (thermal properties, cracking, strength) and durability-related parameters (permeability, detection of voids in prestressing ducts, cover). Many of these are non-destructive methods which provide rapid feedback of information and allow corrective action and decisions to be taken *during* construction. Statistical evaluation of test methods for accuracy, sensitivity and reliability is also important.

This book discusses all these aspects and forms the Proceedings of International RILEM Workshop held in Mainz, Germany in March 1990. Some 35 papers from 13 countries are included. It will be of value to engineers and technologists concerned with improving the quality of concrete construction including materials suppliers, designers, specifiers, contractors,

# 21 IN-PLACE TESTING FOR QUALITY ASSURANCE AND EARLY LOADING OPERATIONS WITH PULLOUT TESTING AND MATURITY MEASUREMENTS

C.G. PETERSEN

Germann Instruments A/S, Copenhagen, Denmark

## Abstract

Pullout testing systems and maturity measurements for quality assurance and early loading operations are briefly reviewed. Correlation data and variability of pullout testing is stated. Present applications are illustrated by a number of test cases based on the statistical evaluation procedure in the Danish Concrete code DS 411 from 1984 and the Danish Standard for Evaluation of Test Results DS 423.1 from 1985 with particular reference to pullout testing in-situ.

## 1. THE NEED FOR IN-PLACE STRENGTH TESTING DURING CONSTRUCTION

The traditional standard cylinder or cube test measures the potential compressive strength of a given mix after 28 days, when the concrete under ideal laboratory conditions is cast, compacted and cured in water or moist at 20°C.

The strength of the structure itself is different, depending on the effects of transportation of the concrete, pumping and casting, compaction and curing as well as the maturity developed on-site.

In an attempt to achieve a more realistic evaluation of the in-situ strength, cylinders or cubes have traditionally been made on-site and cured alongside the structure. The results of such tests are often significant different from the structures and have higher variation, because it is difficult and often impossible to ensure identical casting, compaction, curing and maturity. The results may be directly misleading if the test specimens are mistreated or cured differently than the in-place concrete.

Test results from such traditional testing are matched with a required 28-day strength, which usually is obtained by multiplying the design strength by a factor of 1.5 partly motivated by the wellknown fact that the in-place strength may be lower than the test specimens.



Developments the past 20 years in the world of in-situ testing have resulted in considerable progress to overcome the inherent deficiencies in using standard test specimens for the strength evaluation.

Although in-situ testing with the new techniques attempts to give a direct estimate of the in-place strength and although such testing is much more economic and quick to perform than traditional testing, it is mainly from two special needs the practical applications have originated, namely

- to quality control the critical cover layer for durability to make sure it is well cast, compacted and cured and
- a wish to time early loading of a hardening structure safely.

As far as the first need is concerned, it is wellknown that the quantity of the cover layer protecting the reinforcement is one of several critical factors to ensure a durable structure. If this part is free from unintended porosities, micro- and macro-cracks, the structure will more easily resist the attacks from e.g. chlorides, moist, oxygen, carbondioxide, acids, sulphates and freeze-thaw it was designed for. The traditional standard cylinder or cube test generates no such information. This deficiency may be overcome by testing the critical cover layer after 28 maturity days and compare the results with those of the lab-crete. If they are of the same order and within certain variations, it has been proved that the real-crete has the same quality and homogeneousness as the lab-crete. Otherwise, the reasons for lacking compliance may be found by petrographical analyses and immediate corrective measures taken. From recent experience with modern high strength concretes designed to resist long term chloride chloride attacks, a 50% loss of strength of the cover layer was evidenced caused mainly by insufficient compaction and curing conditions.

Timing of removal of forms, shores and other early loading operations involve the possibility of cutting down on a construction schedule and lead to substantial benefits in terms of more economic use of form materials, saved interest and earlier rentals. Such benefits far exceeds the extra costs usually required by using better concretes than specified, protection of the structure, controlled heating and in-situ testing. Even if parts of an in-situ cast structure, like massive columns quickly develop maturity, a number of flexural and prestressed members do not necessarily develop strength before they are required to accept large percentages of their design loads, especially in cold weather conditions. Also out of safety reasons, such early loading operations require in-situ testing. If such testing indicates adequate strength, e.g. 24 hours after casting, it is evident that the 28-days standard specimen test is only of academic interest.

Both aspects - ensuring durability and achieving early loading - usually requires the use of quality concretes with a potential higher strength than needed from only a 28-day design strength point-of-view. Increasingly the practice has been to use mixes with low w/c-ratios, which gives 50% to 200% higher strength than required from a purely static calculation. This trend makes the 28-day cylinder or cube test even more obsolete as the only means of quality control.

## 2. IN-SITU TEST SYSTEMS

To evaluate the strength in-place a number of different test systems are available today. They comprise hammer testing, ultrasonic, resi-

stance to penetration, break-off, pull-off, internal fracture, push-out cylinders, drilled cores, pullouts and maturity.

The methods differ in terms reliability, reproducibility and accuracy of the strength estimate, simplicity, speed of testing, degree of needed planning and the required training of the testing personnel as well as the degree of destruction and the costs involved.

The methods are described in British Standard BS 1881 or in ACI report 228.1R-89.

Comparisons between the systems calibrations to standard specimen compression tests have during the years been made by a number of researchers around the world, among who Poulsen (1975), Bellander (1979), Malhotra and Carette (1980), Bungey (1982) and Keiller (1982) are some of the most prominent.

### 3. PULLOUT TESTING TIMED BY MATURITY MEASUREMENTS

Pullout testing has during the years attracted special attention because of the excellent correlation obtained between pullout force and standard specimen compression tests. The system is furthermore flexible, simple and quick to use and gives only a minimal destruction to the structure.

The system is today standardized by ASTM (ASTM C-900), British Standard (BS 1881, part 7), International Standard (ISO/DIS 8046), Swedish Standard (SS 137238) and by Danish Standard (DS 423:31).

In the 1970's pullouts were carried out partly using design by Richard (1972) and partly by Kierkegaard-Hansen (1975). Both these systems required special designed inserts to be embedded in the fresh concrete.

Later development by Petersen (1980) allows an insert to be installed at random in the hardening or fully hardened structure. All the experience described and data given in this paper refers to the use of the latter two systems, named LOK-TEST and CAPO-TEST respectively.

Simultaneously with the development of LOK-TEST and CAPO-TEST, Hansen (1981) designed a simple and quick-to-use maturity meter called the COMA-Meter to time the pullouts. This meter is described as well in the following.

Finally a number of testing cases will illustrate the applications of the systems based on the Danish Concrete Code DS 411 from 1984 and the Danish Standard for Evaluation of Test Results DS 423.1 from 1985.

## 4. LOK-TEST AND CAPO-TEST

### 4.1 THE TESTING PRINCIPLE

The testing principle is to measure the force by which a 25mm disc or ring placed in a depth of 25mm is pulled out of the concrete through a 55mm inner diameter counterpressure placed on the testing surface, and relate the pullforce to standard cylinder or cube compressive strength by means of a correlation curve.

The LOK-TEST utilizes a disc embedded in the fresh concrete, the CAPO-TEST a ring to be expanded in a hole undercut as illustrated below.



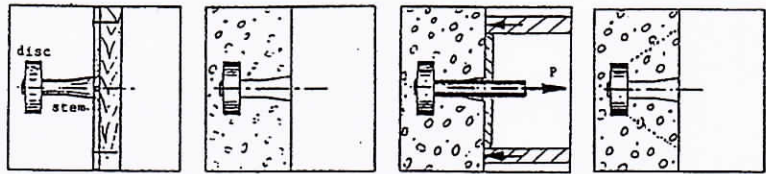

Fig.1 LOK-TEST testing procedure

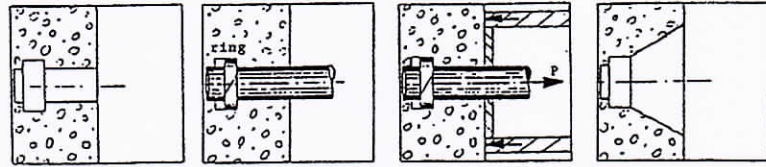

Fig.2 CAPO-TEST testing procedure

#### 4.2 TEST EQUIPMENT

The LOK-TEST disc is threaded to a stem, both parts are threadlocked and coated. The unit is delivered in various configurations depending on the purpose of testing. The L-42 insert with L-44 steel plate is installed on a removable plug drilled out of the form. This allows the plug to be removed and the insert to be tested prior to form removal. The L-40 insert (shown above in figure 1) is installed on a watertight masonite plate nailed to the form. When the form is removed, the plate breaks in the screw-hole or follows the form. Also floating inserts to be embedded in top surfaces are available.

The test equipment consists of a manually operated hydraulic precision equipment, which ensures a constant and uniform loading rate during pullout. The weight of the equipment is 2.5 kg and it is delivered in a small briefcase with all accessories.

Testing with LOK-TEST usually only takes place exactly to failure. Then the test equipment is unloaded and disconnected from the disc, leaving only a slightly raised 55mm ring visible on the surface as shown in figure 3. The surface needs usually not to be repaired.

With CAPO-TEST an 18mm hole is drilled perpendicular to a plane surface outside reinforcement disturbance with a watercooled diamond bit. A router undercuts a 25mm hole 10mm deep in a depth of 25mm from the surface. The folded ring is inserted in the hole and expanded on a special tool in the undercut hole. The same hydraulic equipment as used for LOK-TEST is attached to the tool and activated by hand. Pull-out takes place until the CAPO-TEST failure occurs and the cone is fully dislodged, as shown in figure 4. The cone hole may be repaired with a polymer modified mortar.

The complete test equipment for CAPO-TEST is contained in two small portable briefcases.

One LOK-TEST usually takes 3-5 minutes to perform, CAPO-TEST 10-15 minutes depending on how well trained the testing personnel is.

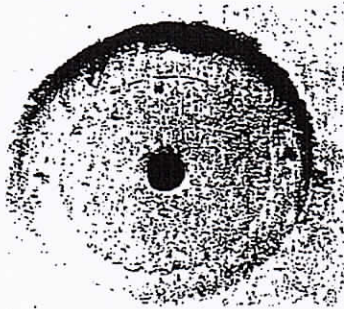

Fig.3 LOK-TEST failure

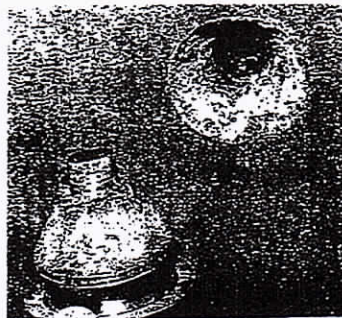

Fig.4 CAPO-TEST failure

#### 4.3 CORRELATION BETWEEN PULLOUT FORCE AND STANDARD SPECIMEN TESTS

The failure mechanism in a pullout is complicated, and it has not so far been possible to calculate convincingly a compressive strength from a given pullout force. Consequently, it has been necessary to compare pullout forces with the so-called uniaxial compressive strength measured on standard cylinders or cubes, to obtain a valid correlation.

Such correlations have been performed during the past 15 years in a large number of series in various countries all over the world.

Three different procedures have been used:

1. 150mm x 300mm (6"x12") standard cylinders have been installed with LOK-TEST inserts in the bottom resting against L-44 steel plates. At the time of testing the inserts are pulled exactly to failure, the cylinder capped and tested in compression. To prevent radial cracking during pullout, the cylinder bottom have been clamped into a steel ring, especially if the maximum aggregate size has been higher than 32mm or the strength measured was higher than 40 MPa. To prevent radial cracking in-place, a minimum distance between inserts and edges or corners has to be 100mm (Petersen, 1984)

Comparative measurements have usually been performed at different maturities, usually after 1, 1½, 2½, 3, 5, 7 and 28 days at 20°C for the particular concrete mix to be used. For each of the mentioned ages it has become practice to test 3 cylinders.

From the data two curves are generated, one with the strength development in dependence of the  $M_{20}$  days (maturity days at 20°C), and another comparing the pullout force in kN to cylinder compressive strength in MPa (or PSI).

This procedure has been predominant in Canada and USA.

2. In Denmark cylinders were cast without inserts embedded. To test for pullout strength separate 200mm cubes were cast, usually with two LOK-TEST inserts placed centrally in opposite vertical faces. The remaining vertical faces were tested with CAPO-TEST.

Both sets of specimens have been cast, compacted and cured as identical as possible, and the testing took usually place at 28  $M_{20}$  days. A wide variety of concrete parameters were used in the concrete mixes as later described.



3. In Sweden, Norway, the Netherlands, England and the Gulf Countries the normal procedure has been to cast two sets of 150mm cubes, test one in compression and the other with LOK-TEST or CAPO-TEST centrally placed on opposite vertical faces. In some correlations 200mm cubes were used for pullout testing or a steel frame was used to secure the 150mm cube in before pullouts, especially if large aggregates were used or at higher strength ranges.

Testing were carried out in some cases at various maturities and in other test series at 28 M<sub>20</sub>-days.

In the test series conducted it was found that the use of lightweight aggregates influenced the position of the correlation significantly. For all other parameters investigated the correlation was found to be stable as indicated in the figures 5 and 6. The parameters investigated were: w/c-ratio, type of cement, curing conditions (water cured, water and air cured and mistreated), maturity and age, source/form/size of aggregates (up to 38mm maximum aggregate size), fibers, air-entrainment, flyash and microsilica content.

The findings from 24 such major correlation series are reported on the following page from Krenchel & Petersen (1984).

The coefficient of correlation ranged from 0.91 to 0.99, typically it was 0.95.

Krenchel (1982), Bellander (1983) and Bungey (1983) found similar correlations for LOK-TEST and CAPO-TEST compared to uniaxial compressive strength.

Later correlations made after 1984 have shown the same general connexion between pullout force and uniaxial compressive strength as indicated in the figures 5 and 6.

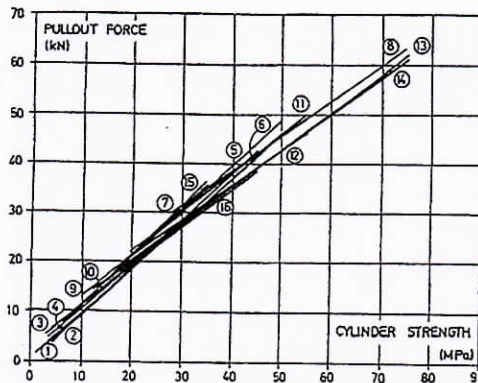

Fig. 5 Sixteen correlation series between pullout force in kN and 150mm x 300mm (6"x12") standard cylinder compressive strength in MPa. (3041 pullout- and 2067 cylinder tests)

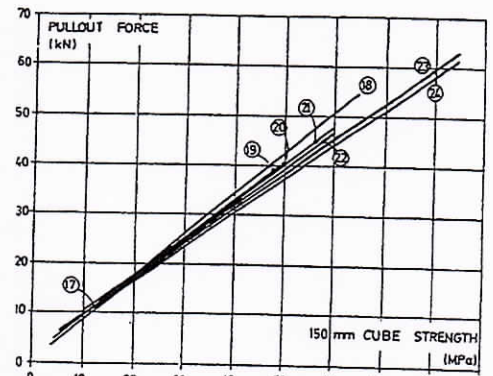

Fig. 6 Eight correlation series between pullout force in kN and 150mm (6") standard cube compressive strength in MPa. (1087 pullout- and 860 cube tests)

A statistical analyses of the data gives the correlations shown in figures 7 and 8. The deviation between those recommended correlations and any of the ones indicated in figures 5 and 6 is within 10%.

The precision of the pullout test is shown in figure 7 based on Danish data for 16mm and 32mm maximum aggregate size and in figure 8 for 18mm and 38mm maximum particel size calculated from Swedish data.

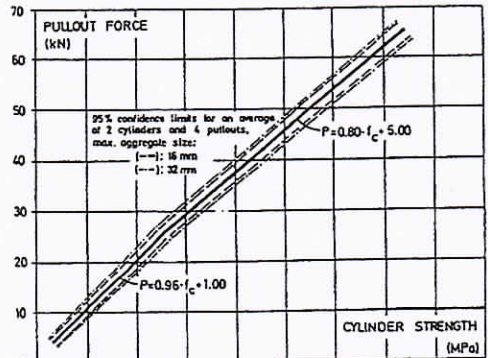

Fig. 7 Recommended correlation between pullout force in kN and 150mm x 300mm (6\"/>

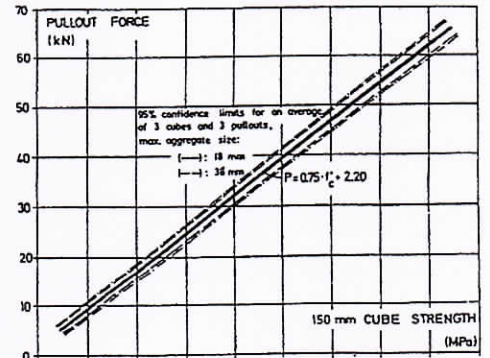

Fig. 8 Recommended correlation between pullout force in kN and 150mm (6\"/>

It should be mentioned that if correlations are carried out on the structure by comparing pullout force with compression tests of drilled out cores, deviations from the above found correlations to standard specimen compression test may be found, depending on the quality of the cover layer compared to the quality of the concrete at the depth where the cores are taken. Also the curing conditions (dry or wet) of the cores before testing is important as well as the diameter size and the height-diameter relationship. One example of such a calibration is given in Rockström and Molin (1989). They compared CAPO-TEST to 100mm x 100mm cores on a number of Swedish bridges. The cores were air cured 3 days in the laboratory before testing.

#### 4.4 VARIATION OF PULLOUT TESTING

The variation of pullouts have been investigated and reported by Bickley and Fasullo (1981), Bickley (1982) and Krenchel and Petersen (1984). The results are summarized below for laboratory testing as well as testing in-situ with the standard deviation "s", coefficient of variation "v" and the number of tests "n" stated.

##### Laboratory testing:

Table 1. Variability of concrete specimens cast in the laboratory

Specimens	PULLOUT TEST			REF. COMPRESSION TEST		
	s (kN)	v (%)	n	s (kN)	v (%)	n
1) Pullout vs. standard cylinder	1.9	7.5	957	1.7	6.4	994
2) Pullout vs. standard cylinder	2.8	9.9	2084	1.6	4.2	1073
3) Pullout vs. standard cube	2.5	6.8	1087	2.4	6.2	860
4) Pullout vs. cores (shotcrete)	1.3	4.5	125	4.4	8.9	36

1) Cylinders used for both pullout force and compression strength determination. Pullout test positioned in cylinder bottom.  
 2) Pullouts positioned centrally on two opposite vertical faces of 200mm cubes. Standard cylinders cast separately without embedded inserts for pullout.  
 3) Pullouts positioned centrally in one vertical face of 150mm cubes, if tested at higher strength levels 200mm cubes were used. Separate 150mm cubes without pullout inserts were used for compressive strength determination.  
 4) Pullout force measured on top-part of horizontal shot panels in the laboratory. 80mm x 160mm cores were used for compression tests.



The cylinders and the 150mm cubes were always cast in three layers, each compacted on vibration table. The 200mm cubes were also cast in three layers, but compacted using hand-rodding.

In-situ testing:

Table 2. Variability of concrete elements on-site

Type of element	PULLOUT TEST		
	S (kN)	v (%)	n -
Beams and columns	2.7	7.8	325
Slabs, bottom part	3.1	9.7	4190
Walls and foundations	3.2	10.0	753
Slabs, top part	3.5	12.5	274
Shotcrete, walls	4.0	13.4	150
Dubious structures	4.5	14.7	1001

The category "dubious structures" mentioned in table 2 comprises for example construction elements having been subjected to fire, acids, alkali-silica reactions, freezing at an early age, temperature cracking or bad cast, consolidated and cured elements.

4.5 FAILURE MECHANISM INVESTIGATIONS

To explain the excellent correlations found between pullout force and uniaxial compressive strength, the failure mechanism has during the years been investigated by a number of researchers, of who three will be mentioned in the following.

Jensen and Bræstrup (1976) investigated first the failure mechanism by means of Coulombs criterion for sliding failure. They concluded, that the pullout force in a LOK-TEST is directly proportional to the compressive strength of concrete.

Ottosen (1981) used a non-linear finite element analyses to describe the failure mechanism. His conclusion is, "that large compressive forces run from the disc in a rather narrow band towards the counterpressure, and this constitutes the load-carrying mechanism. Moreover, the failure in a LOK-TEST is caused by the crushing of the concrete and not by cracking. Therefore, the force required to extract the embedded steel disc is directly dependent on the compressive strength of the concrete in question," Ottosen (1981, pp. 602).

Krenchel and Shah (1985) investigated experimentally the crack formation in a LOK-TEST. The findings are further referred in Krenchel and Bickley (1987). The conclusion is, see figure 9.

"The internal rupture during this type of test is a multi-stage process where three different stages with different fracture mechanisms can be clearly separated. In the first stage, at a load level of about 30-40% of the ultimate load, tensile cracks are formed starting from the notch formed by the upper edge of the pullout disc. These cracks are running out in the concrete with a very open angle (cone angle between 100° and 135°). The total length of this first crack is typically some 15 to 20mm from the edge of the disc. As a result of this first stage cracking, the material between the top face of the pullout disc and the bottom face of the counter pressure ring is now free, so that straining

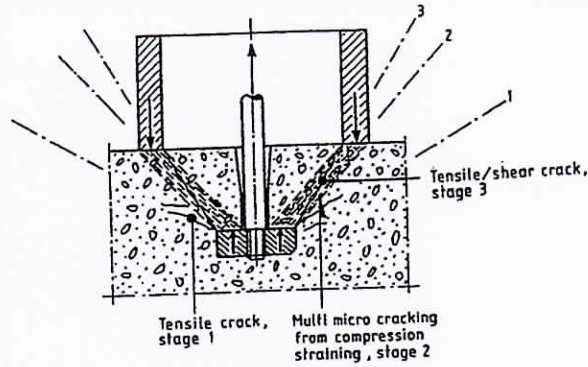

Fig.9. Internal cracking stages during a pullout

in the material is now concentrated and all load is taken up in the truncated zone between the two plane faces. In the second stage of internal rupture a multitude of stable microcracks are formed in the above mentioned truncated zone, the main direction of these cracks running from the top of the disc to the bottom of the ring forming a cone angle of approximately  $84^\circ$ . The formation of this second cracking pattern is very much parallel to the formation of more and more vertical microcracks inside a concrete cylinder or prism during ordinary uniaxial compressive tests. Development of the acoustic emission activity during this second stage of the test also follows an exponential function quite parallel to the AE-development in ordinary uniaxial compressive tests. If more and more oil is pumped into the pullout jack, even after the load has stabilized at the peak point, then the third stage of internal rupture occurs by the formation of a tensile/shear crack all the way around, running from the outside edge of the disc to the inside edge of the counter pressure ring and forming the final pullout cone with a cone angle of about  $62^\circ$ , Krenchel and Bickley (1987, pp. 165-166).

Krenchel concludes (1987, pp. 167): "As the micro cracking of stage number two is responsible for and directly related to the ultimate load in this testing procedure, it seems quite logical that such close correlations with the concrete compressive strength is always obtained."

#### 4.6 RECOMMENDED CORRELATION PROCEDURE

For quality control of the cover layer, it has become practice in Scandinavia to use the recommended general correlations as illustrated in figure 7 and figure 8, for LOK-TEST as well as for CAPO-TEST.

Also the relationships are used for timing of early loading of in-situ cast structures in England, in Canada, USA and the Benelux.

However, it is still a good idea to correlate ones own particular concrete mix in a pre-testing program prior to starting up a major project, and compare the results with the data in this paper. The following rules should be observed when performing such a correlation:

- a. The correlation ought to be conducted over a span of at least 35 MPa strength range. Otherwise the slope of the curve will not be determined with sufficient precision.
- b. One correlation should consist of minimum 7 clusters of corresponding observations, equally distributed in the strength range decided upon.



- c. Each cluster should consist of the following minimum number of specimens, alternatively:
- c-1. One set of three 150mm x 300mm cylinders with LOK-TEST L-42 inserts/L-44 steel plates in the bottom or
  - c-2. One set of two 150mm x 300mm cylinders and two 200mm cubes with two LOK-TEST L-42 inserts in each, placed centrally on two opposite vertical faces. The remaining two faces may be used for CAPO-TEST or
  - c-3. One set of three 150mm cubes with LOK-TEST L-42 inserts placed centrally in one vertical face or
  - c-4. One set of two 150mm cubes and two 200mm cubes with two LOK-TEST L-42 inserts in each, placed centrally on two opposite vertical faces. The remaining two faces may be used for CAPO-TEST.
- d. The specimens should be cast, compacted (preferably on vibration table) and cured in water at 20°C; identically.
- e. The seven sets of specimens may be tested at the following maturities: 1, 1½, 2½, 4, 7, 14 and 28 M<sub>20</sub> days, one set at each maturity.
- f. If the specimens for compression tests contain a LOK-TEST L-42 insert, the testing is performed by first pulling the insert exactly to failure and no further, record the pullout force and then compress the specimen with the face containing the insert resting against one of the test machine compression plates, e.g. after capping (of cylinders).
- g. From the test data two curves are generated,
- one comparing pullout force to compressive strength using linear regression analyses and calculation of the coefficient of variation and the coefficient of correlation,
  - another showing the strength development in relation to maturity days (M<sub>20</sub>-days).

The first relationship is compared with the general recommended correlations in this paper (figure 7 or figure 8). The second is used for timing of pullouts with maturity before early loading operations. If e.g. the required strength is supposed to be present in the structure after 1.5 M<sub>20</sub>-days, the COMA-Meter described in the following has to show 1.5 M<sub>20</sub>-days before the pullout testing takes place. By using this procedure, not only the potential strength of the structure is checked, but also the actual strength before critical early loading operations is measured in-place.

#### 5. COMA-Meter

The COMA-Meter (Concrete Maturity-Meter) was developed to measure accurate, simple and quick the maturity of in-place concrete without troublesome daily temperature registrations or sensible electronic maturity computers involved.

The meter follows the Arrhenius equation for maturity

$$M_{20} = \int_0^t \exp\left(\frac{E}{R} \left(\frac{1}{293} - \frac{1}{T(t)}\right)\right) dt \quad (1)$$

with an accuracy as indicated in table 3. E is the activation energy chosen to 40 kJ/mol, R the gas constant (kJ/mol °K) and T the temperature (°K).

Table 3. The accuracy of the COMA-Meter compared with maturity after the Arrhenius equation ( $M_{20}$  after one day).

Temp. °C	Arrhenius ( $M_{20}$ )	COMA-Meter ( $M_{20}$ )
-5	0.07	0.17
0	0.15	0.26
5	0.29	0.37
10	0.50	0.50
15	0.75	0.71
20	1.00	1.00
25	1.26	1.17
30	1.57	1.54
35	1.95	2.00
40	2.41	2.57
50	3.58	4.13

The COMA-Meter, shown in figure 10, operates by breaking a closed capillary tube filled with a special liquid at zero, when the concrete has been cast in-place. The tube is placed on a scale which is inserted a container. The meter is pressed into the concrete and the temperature inside the meter will stabilize with the concrete after 10 minutes. The liquid in the capillary will start evaporating and the level will on the scale indicate the number of days the concrete is old at 20°C. The maturity may be read by unscrewing the scale from the container at any time. Afterwards the scale is reinserted and the integration of time and temperature will continue.

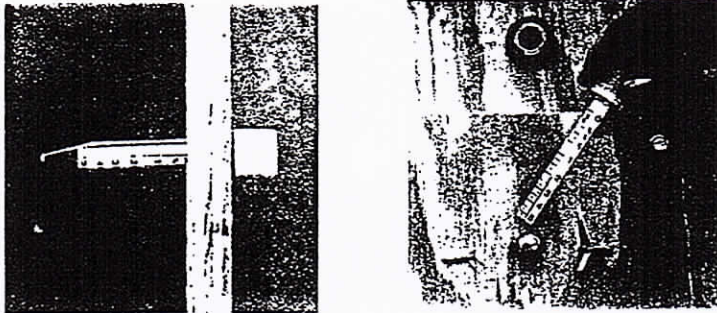

Fig.10. The COMA-Meter

Two measuring ranges are available, either 0 to 5.5  $M_{20}$  days or 0 to 14  $M_{20}$  days.

The COMA-Meter is described in detail in Hansen (1981).



## 6. TESTING CASES

Pullout testing is today mainly used for quality control of new structures or elements, for timing of early loading operations or for evaluation of the residual strength of old concrete structures.

In the following a number of testing cases will illustrate the applications within the first two categories. Evaluation of the results are based on the statistical evaluation procedure outlined in the Danish Concrete Code DS 411 from 1984 and the Danish Standard for Evaluation of Test Results DS 423.1 from 1985. A brief summary of the evaluation procedure is given in appendix 1.

Only "variable control" will be mentioned leaving out "alternative control", since pullout testing in practice almost always is performed to the maximum peak-load and not only to a required level. This is partly caused by the testing personels curiosity "to learn what the concrete strength really is", and partly that the CAPO-TEST cones always have to be pulled out. However, if LOK-TEST is only used, the simple "alternative control"-procedure may as well be used.

### 6.1 QUALITY ASSURANCE BY CONTROL IN TOTAL

A slab in an office building suffered from severe cracking in a 10 m<sup>3</sup> pour. The slab was one week old.

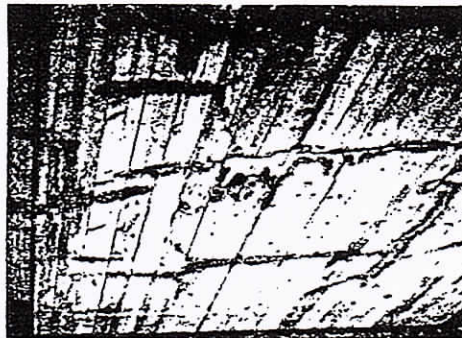

Fig.11. Fully cracked slab from below

The consulting engineer ordered the slab to be tested in-situ to make sure the specified 28-day strength  $f_c=20$  MPa was present in-place.

The pour consisted of concrete from three truckloads. It was decided to test each truckload with three CAPO-TEST from the top of the slab.

The maturity of the concrete was not measured by the contractor. The daily temperatures was procured from the Institute of Meteorology and the maturity was estimated to be 35 M<sub>20</sub> days at the time of testing on the assumption of a slightly higher temperature two days after casting. Since the specified strength 20 MPa was supposed to be present 28 M<sub>20</sub> days after casting, the measured in-place strength was corrected according to the maturity curve in appendix 2 for the cement type used, rapid cement.

The testing was carried out as illustrated in figure 12 after the reinforcement was located and the rough surface ground smooth and plane.

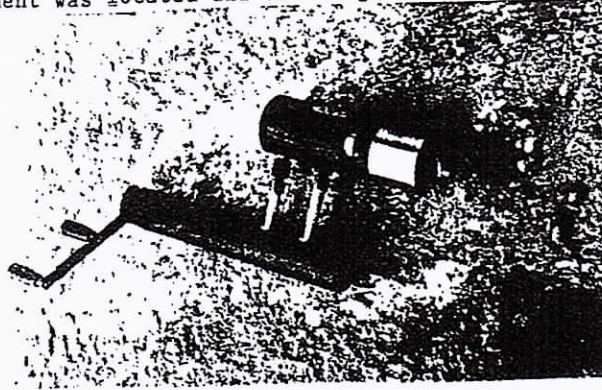

Fig.12. Completed CAPO-TEST

The test results are exhibited in table 4.

Table 4. Test data from in-situ testing with CAPO-TEST on cracked slab

CAPO-TEST No.	CAPO-Strength (35 M20) (kN)	Cyl.strength (35 M20) (MPa)	Corr.factor $\bar{x}$	Cyl.strength (28 M20) (MPa)	Observation Average (MPa)
1	21,9	21,8	0,95	20,8	18,2
2	18,3	18,0	0,95	17,1	
3	17,8	17,5	0,95	16,7	
4	17,2	16,9	0,95	16,1	17,5
5	16,7	16,4	0,95	15,6	
6	21,9	21,8	0,95	20,8	
7	22,4	22,3	0,95	21,2	21,7
8	23,9	23,9	0,95	22,8	
9	22,4	22,3	0,95	21,2	

As no of the observation were lower than 80% of the 20 MPa, the slab was accepted to be in compliance with DS 411 and DS 423.23.

The testing lasted 2½ hours. The consulting engineer received the test report the following morning.

The ready mix plant supplying the concrete reported two days later the cylinder results. The average was 22.5 MPa with almost no variation involved.

#### 6.2 QUALITY ASSURANCE BY SAMPLE TESTING

In the specifications for a rainwater reservoir it was stated that the in-place concrete had to be tested with LOK-TEST to make sure the construction could resist attacks from chlorides specially during the winter period, where chlorides would be present in the water from de-icing salts.

The reservoir contained 34 truckloads of concrete in the bottom slab, the walls and the top slab. Eight of the truckloads were specified to be tested at random.



The testing was carried out at 15 M<sub>20</sub> days (test no. 1-6) and at 35 M<sub>20</sub> days (test no.7-8) indicated by the COMA-Meter.



Fig.13. Testing of bottom slab with LOK-TEST and COMA-Meter.

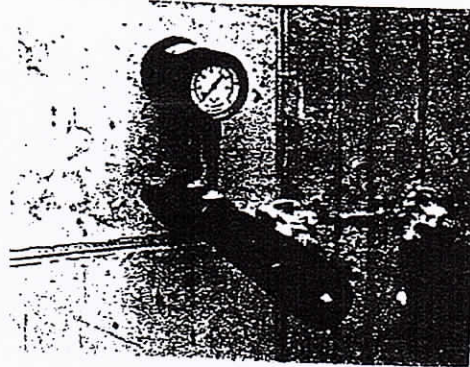

Fig.14. Testing of wall with LOK-TEST

The results are indicated in table 5.

Table 5. Test data from in-situ testing with LOK-TEST of rainwater reservoir

LOK-TEST No.	LOK-Strength (kN)	Cyl. strength (MPa)	Maturity (M <sub>20</sub> )	Corr. factor $\gamma$	Cyl. strength (28 M <sub>20</sub> ) (MPa)
1	35,2	37,8	15	1,05	39,8
2	38,8	42,3	15	1,05	44,5
3	27,9	28,6	15	1,05	30,1
4	36,2	39,0	15	1,05	41,1
5	34,3	36,6	15	1,05	38,5
6	35,2	37,8	15	1,05	39,8
7	36,3	39,1	32	0,96	37,5
8	38,3	41,6	32	0,96	39,9

$$\bar{f}_c = 38,9$$

It should be noticed that test number 3 was a floating L-49 LOK-TEST inserts with a major air accumulation below the test surface caused by wrong installation by the contractor. He could have chosen to conduct a CAPO-TEST instead, but wanted to stick to the low result as it had no influence on the acceptability of the concrete.

The specified strength in-place was 35 MPa. With an undocumented coefficient of variation of  $v=0.16$  and the number of tests  $n=8$ , the  $k_n$  factor is 1.27. This means that the mean strength in-place at least has to be

$$\bar{f}_c \geq 0.8 \cdot k_n \cdot f_c = 0.8 \cdot 1.27 \cdot 35 = 35.6 \text{ MPa}$$

As the measured mean strength was 38.9 MPa the structure was accepted to be in compliance with DS 411 and DS 423.1.

The testing took one hour and the contractor received the testing report the following morning.

The laboratory cylinder results averaged 39.6 MPa.

### 6.3 EARLY LOADING BY CONTROL IN TOTAL

A bridge box girder had to be tensioned in segments. The following example is from one of the segments being cast and tensioned in cold weather conditions.

One segment contained 10 truckloads. In the truckload close to the anchor zone four LOK-TEST inserts were installed, while the remaining contained one insert in each. Type L-40 and L-42 inserts were used.

COMA-Meters were installed through the formwork or from the top of the slab, one close to each LOK-TEST inserts.

The specified strength before tensioning was  $f_c=30$  MPa. As every truckload was tested, the type of control was "control in total" and consequently all observations had to be higher than 80% of 30 MPa, before tensioning could take place.

The segment was covered and insulated after casting. Heating from inside of the box girder was applied. The outdoor temperature was  $-5^\circ\text{C}$  with very strong windy conditions.

Three extra installed LOK-TEST inserts were tested after 3.0 M20 days, averaging 28.1 MPa.

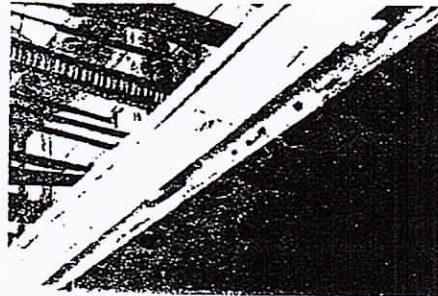

Fig.15. LOK-TEST inserts type L-40 installed close to the anchor zone ready for test.



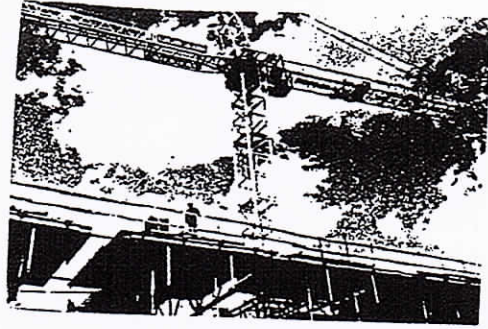

Fig. 16. Flying form system

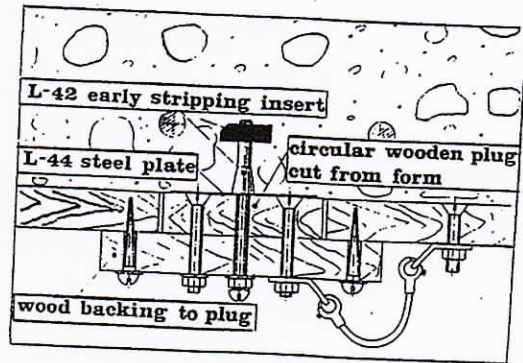

Fig. 17. Principal installment of L-42 inserts with L-44 steel plate through slab forms.

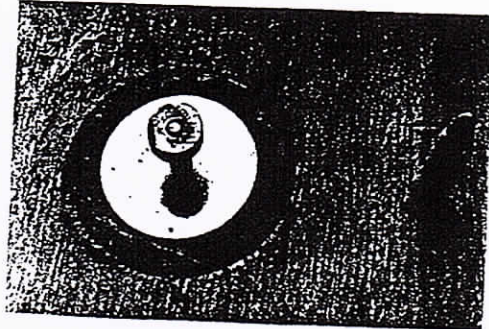

Fig.18. LOK-TEST L-42 insert with L-44 steelplate installed in slab formwork together with one COMA-Meter (seen from casting side).

As the COMA-Meters close to the LOK-TEST inserts all showed minimum 3.0 M<sub>20</sub> days, it was decided to test the 14 installed LOK-TEST inserts.

Table 6. Test data from in-situ testing with LOK-TEST of segmental box girder.

LOK-TEST No.	LOK-Strength (kN)	Cyl. strength (MPa)	Observation (MPa)
1	29.7	30.9	30.9
2	30.3	31.6	31.6
3	28.1	28.9	28.9
4	27.0	27.5	27.5
5	27.0	27.5	27.5
6	26.8	27.3	27.3
7	27.5	28.1	28.1
8	27.2	27.7	27.7
9	28.3	29.1	29.1
10	31.8	33.5	
11	30.6	32.0	
12	28.7	29.6	30.0
13	27.8	28.5	
14	26.2	26.5	

Since all observations in-place were higher than the required strength 24 MPa, the consulting engineer accepted the segment to be tensioned, a operation which took place right afterwards.

The testing took 65 minutes.

At the time of testing with pullouts, the contractor tested six cylinders cast on-site and cured on the bridge slab under wet blankets covered with insulation mats and a pile of sand. The average strength of the cylinders was 37.5 MPa. The maturity of the cylinders was not measured.

#### 6.4 EARLY LOADING BY SAMPLE TESTING

Each floor in a 33 storey office building contained 520 m<sup>3</sup> of concrete. Every pour consisted of a 75 m<sup>3</sup> casting. The data reported in the following is taken from one such typical pour.

Ten LOK-TEST inserts type L-42 were installed in the flying form system equally distributed throughout the casting and placed in the middle between the supporting columns.

Two COMA-Meters were mounted in the formwork, one at the beginning of the pour and one at the end.

As one truckload contained 4.5 m<sup>3</sup> of concrete, every truckload would not be tested. Consequently the type of control was control by sample testing.

The specified strength was 28 MPa (28-days). The required average strength before form removal was 21 MPa. The contractor decided to use a 35 MPa concrete to speed up the early age strength gain.

The in-place strength of the pour had to average as a minimum:



$\bar{f}_c = 0.8 \cdot k_n \cdot f_c = 0.8 \cdot 1.37 \cdot 21 = 23.0 \text{ MPa}$   
 with a  $k_n$  factor of 1.37 calculated from appendix 1 based on an undocumented coefficient of variation  $v=0.19$  and the number of test  $n=10$ .

From earlier experience with the concrete mix chosen it was known, that the strength was supposed to be present in the slab after 1.8 M<sub>20</sub> days if the real-crete had a potential strength as intended and the pumping, the casting, the compaction and the curing was carried out as normally.

The testing with pullouts took place after the COMA-Meter placed at the end of the pour showed 1.8 M<sub>20</sub> days. The result are given in table 7.

Table 7. Test data from in-situ testing with LOK-TEST of slab prior to early form removal

LOK-TEST No.	LOK-Strength (kN)	Cyl. Strength (MPa)	Maturity (M <sub>20</sub> )
1	25.2	25.2	2.0
2	24.4	24.4	-
3	22.2	22.1	-
4	25.8	25.8	-
5	21.0	20.8	-
6	25.2	25.2	-
7	26.5	26.9	-
8	27.0	27.5	-
9	24.5	24.5	-
10	25.8	25.8	1.8

$f_c = 24.8 \text{ MPa}$

As it will be seen, the average strength in-place at the time of testing was 24.8 MPa which surpassed the required strength of 23.0 MPa. The flying form system was removed after acceptance of the test results and the calculations by the consulting engineer. Immediately afterwards the slab was supported by shores to prevent deflection.

The pullout testing lasted 1½ hour and since the inserts cast-in only were pulled exactly to failure, no repair was needed. The preliminary cutting of portholes in the formwork took 3 hours.

## 7. DISCUSSION

Usually it is the owner of the structure who decides to use pullout testing for quality assurance. Similar it is the contractor who is interested in performing early loading operations. Conflicts of interest are not unusual in such situations.

To overcome such conflicts it is a very good idea to arrange a short one day course where the theoretical background, the systems operation, the equipments, the practical testing, the sources of error, the flow of information, the decision authority and the costs/benefits are illustrated and discussed. All the parties in the contract should participate at management level. It is also a very good idea prior to a project involving pullout testing to train the testing personel in correct installment of inserts and meters, in the practical testing on-site and in maintenance of the equipment. This may be done on a one to two day course, preferably at the site.

The world of concrete testing is very conservative. Deeply rooted habits and ideas are not changed overnight, not to speak of building codes, standards of testing and evaluation procedures.

But it is the authors' experience that if the users understand the basic purpose of the systems illustrated, the functioning of the test equipments and the proper required maintenance, and after they have realized how reliable, simple and quick the systems are, the usual reaction is to ask why this type of testing has not substituted cylinders or cubes long time ago.

The successor exist, she is young - only 20 years - experienced, quick and reliable, and then the structure itself is tested without guesswork or assumptions involved.

#### 8. REFERENCES

- Bellander, U. (1979): "Quality control of concrete structures", RILEM, Part 1, 2 & Proceedings, Swedish Cement and Concrete Research Institute, Stockholm, June 17-21 1979.
- Bellander, U. (1983): "Quality Control of Concrete Structures", Nordisk Betong, No.3-4, 1983.
- Bickley, J.A. & Fasullo, S. (1981): "Analyses of Pullout Test Data from Construction Sites", Transportation Research Board, Washington, D.C., 1981.
- Bickley, J.A. (1982): "The Variability of Pullout Tests and In-Place Concrete Strength", Concrete International, Vol.4, No.4, April, 1982.
- Bungey, J.H. (1982): "Testing of Concrete in Structures", Surrey University Press, Glasgow, 1982.
- Bungey, J.A. (1983): "An Appraisal of Pullout Methods for Testing Concrete", Proceedings of the International Conference on Non-Destructive Testing, Engineering Technics Press, London, 1983.
- Hansen, A.J. (1981): "COMA-Meter - The Mini Maturity Meter", Nordisk Betong, No.4, 1981.
- Jensen, B.C. & Bræstrup, M.W. (1976): "LOK-TEST Determine the Compressive Strength of Concrete", Nordisk Betong, No.2, 1976.
- Keiller, A.P. (1982): "Preliminary Investigation of Test Methods for the Assessment of Strength of In-Situ Concrete", Technical Report No. 42.551, Cement and Concrete Association, Wexham Springs, 1982.
- Kierkegaard-Hansen, P. (1975): "LOK-Strength", Nordisk Betong, No.3, 1975.
- Krenchel, H. (1982): "LOK-Styrkeprøvning og CAPO-Styrkeprøvning af Betons Trykstyrke", Department of Structural Engineering, Technical University of Denmark, Serie I, No.71, 1982.
- Krenchel H. & Petersen, C.G. (1984): "In-Situ Pullout Testing with LOK-TEST, Ten Years Experience", Proceedings, International Conference on In-Situ/NDT Testing of Concrete, Canmet, ACI, CSCE & NBS, Ottawa, October 1984.



- Krenchel, H. & Shah, S.P. (1985): "Fracture Analyses of the Pullout Test", RILEM, Materials and Structures, Research and Testing, No. 108, November-December, 1985.
- Krenchel, H. & Bickley, J.A. (1987): "Pullout Testing of Concrete", Nordic Concrete Research, The Nordic Concrete Federation, No.6, 1987.
- Malhotra, V.M. & Carette, G. (1980): "Comparison of Pullout Strength of Concrete with Compression Strength of Cylinders and Cores, Pulse Velocity and Rebound Number", ACI Journal, Proceedings V.77, No.3, May-June, 1980.
- Ottosen, N.S. (1981): "Nonlinear Finite Element Analyses of Pullout Test", Proceedings, ASCE, V.107, ST4, 1981.
- Petersen, C.G. (1980): "CAPO-TEST", Nordisk Betong, No.5-6, 1980.
- Petersen, C.G. (1984): "LOK-TEST and CAPO-TEST Development and Their Applications", Proceedings, Institution of Civil Engineers, Part I, 76, May, 1984.
- Richard, W. (1972): "Pullout Strength Tests of Concrete", Research Paper, ACI, Annual Meeting, Dallas, Texas, USA, 1972.
- Poulsen, P.E. (1975): "Vurdering af Betons Styrke med Konstruktionsprøvning, LOK-Prøvning, Udborede Kerner, Støbte Cylindre, Ultralyd-Betonhammer Kombineret, Betonhammer og Ultralyd", Danmarks Ingeniørakademi, Bygningsafdelingen, RAM-Rapport Nr. 75:64, Del 1-2, November 1975.
- Rockström, J. & Molin, C. (1989): "Begränsad Studie av Sambandet mellan Hållfasthet mätt med Studshammera, CAPO-TEST resp. Utborede Betongcylindrar", Statens Provningsanstalt, Byggnadsteknik, Arbetsrapport Nr.17, Stockholm, 1989.

## APPENDIX 1

### EVALUATION OF THE STRENGTH OF CONCRETE IN-PLACE BY MEANS OF THE DANISH CONCRETE CODE DS 411 AND THE DANISH STANDARD FOR EVALUATION OF TEST RESULTS DS 423.1 WITH LOK-TEST AND CAPO-TEST

It is described how the in-situ concrete strength may be evaluated. The review is based on the requirements in the Danish Concrete Code DS 411 from 1984 and the Standard for Evaluation of Testresults DS 423.1 from 1985 together with practical experience.

#### 1. APPLICATIONS

##### 1.1 PULLOUT TESTING WITH LOK-TEST

Pullout testing with LOK-TEST may be used for

- Quality assurance of in-situ strength according to the requirements outlined in the concrete specification for a given control section.
- Timing of early loading for concrete elements like early form stripping, tensioning or cutting of strands.

##### 1.2 PULLOUT TESTING WITH CAPO-TEST

Pullout testing with CAPO-TEST is used for

- Supplementary testing needed if the concrete a control section has been rejected by LOK-TEST
- Testing of a control section where no LOK-TEST inserts have been installed
- Supplementary testing if LOK-TEST inserts have been installed erroneously
- Testing of a control section where it is complicated or troublesome to install LOK-TEST inserts, like in slipformed surfaces, trowelled top surfaces, if the concrete is dry or if gunite or vacuum-concrete has to be tested

#### 2. CHOISE OF CONTROL SECTION

##### 2.1 WHO DECIDES THE SIZE OF A CONTROL SECTION?

When the purpose is to quality assure a structure, the size of the control section is decided by the design engineer.

For early loading of elements, the size of a control section is chosen by the contractor together with the supervisor. A control section may typically be one pour.

When decided, the contractor may always sub-divide a control section, if he finds it necessary. On the other hand, the contractor is not allowed to add up several single control sections into one and evaluate them together.

##### 2.2 BATCHES

A control section will consist of a number of batches. For a control section of concrete one batch is the uniform amount of con-



crete either from one mixing charge at the mixing plant or from one truckload being supplied to the site.

### 2.3 THE SIZE OF A CONTROL SECTION

The delimitation of a control section is decided from the following criterions:

- The material property of the concrete and other characteristics is aimed to be uniform in the section.
- A control section must not contain more than 200 batches.
- A control section must be cast in one continuous working operation. No change in the production or transition to other material constituents, e.g. admixtures, is allowed.
- The size of the control section has to be evaluated in relation to the consequence of rejection. However, the contractor may subdivide a control section in this case.

### 3. INSTALLMENT OF LOK-TEST/CAPO-TEST INSERTS

The following rules are applied for positioning of pullout inserts:

- At least 6 tests must be conducted in a control section, randomly distributed.
- Inserts placed in one batch constitutes one test.
- One test may consist of one LOK-TEST/CAPO-TEST insert, but it is recommended to use minimum 2 inserts per test.
- Whatever the number of minimum inserts is chosen, all inserts in one test are placed at the same horizontal level.
- Inserts are placed with a 100 mm minimum distance to edges or corners and at least 30 mm from reinforcement.
- The mutual distance between inserts in one test must be maximum 300 mm and minimum 200 mm.
- Foreign bodies are not allowed in the failure zone.

### 4. OBSERVATIONS

One observation is defined as the average of the pullout forces of one tests single test results. One test may be one LOK-TEST or CAPO-TEST, but it is recommended that a minimum of two are carried out. If several tests are performed within each placed batch, the average constitute the observation.

### 5. MINIMUM SAMPLE SIZE

If the number of observations are less than the number of batches in the control section the number of observations are called the sample size of the control section. The required sample size depends on the number of batches in a control section as follows

No of batches	Minimum sample size
1-3	control in total
4-15	3
16-21	4
22-27	5
28-33	6
34-40	7
41-47	8
48-54	9
55-62	10
63-70	11
71-78	12
79-87	13

No of batches	Minimum sample size
88-96	14
97-105	15
106-114	16
115-123	17
124-132	18
133-141	19
142-150	20
151-160	21
161-170	22
171-180	23
181-190	24
191-200	25

## 6. MATURITY AT THE TIME OF PULLOUT TESTING

### 6.1 REQUIREMENT

The specified strength of the concrete in a control section has to be met 28 M<sub>20</sub> days after casting if the purpose is to quality assure a structure.

For timing of early loading of a structure, the required number of maturity days before pullout testing is executed is found by pre-testing of the concrete mix in the laboratory.

### 6.2 MEASUREMENT OF THE MATURITY

The maturity of the concrete is measured in a depth of 30-40 mm from the surface and close to the pullout test, the recommended distance being 250 mm. If the concrete of one placed batch has the same maturity it is allowed to place one maturity meter or sensor in the casting.

### 6.3 CORRECTION OF PULLOUT RESULTS FOR QUALITY ASSURANCE

If the concrete maturity deviates maximum plus minus 20% from the required 28 M<sub>20</sub> days it is allowed to correct the pullout results to the required 28 M<sub>20</sub> days strength, if a documented relationship exists between the strength and maturity for the particular cement type used.

Such documented relationships for Aalborg Portlands three different types of cement are outlined in appendix 2.

## 7. NORMAL REQUIREMENTS

The required concrete strength in a control section is stated in the specification for the concrete structure in question. The minimum required strength depends of the so-called "class of protection" as given in Danish Standard DS 411.

### 7.1 CHARACTERISTIC STRENGTH

The characteristic strength  $f_c$  by testing cylinders (DS 423.23) has to meet the specifications.

This requirement may be superseded if durability demands a required w/c-ratio leading to a higher strength than required by Danish Standard DS 411. It is not unusual that higher requirements are stated in the concrete specification than outlined by the minimum requirements in DS 411. It may be an economic advantage to make use of the higher strength required because of an aggressive environment. A similar circumstance may exist if the purpose is to time early loading operations and a concrete with high early strength gain is selected exceeding the specified 28-day cylinder strength.

If the static calculations demands a higher strength than required by the minimal requirements in DS 411, this should be stated clearly in the specification for the concrete structure.

### 7.2 TWO-SIDED CONTROL

Where a homogeneous concrete strength is required, the specification may contain a required upper and lower limit within of which range the strength values have to be situated. Two-sided control of the concrete strength will usually require the application of "alternative control" illustrated later, since "variable control" is too complicated for this application.

### 7.3 IN-SITU TESTING

The Danish Standard DS 411 states, that a strength requirement is met if the structure is tested in-situ, if 80% of the cylinder strength is achieved.



## 7. CONVERSION EQUATIONS

The following equations may be regarded as general relationships for concrete with a maximum aggregate size less than 38 mm. The relationships applies for normal concrete, only not for the use of lightweight aggregates.

- 7.1 PULLOUT FORCE TO 150mm x 300mm CYLINDER COMPRESSIVE STRENGTH  
The conversion equation between pullout force P in kN and 150mm x 300mm cylinder compressive strength  $f_c$  in MPa is recommended as:

$$P = 0.96 \cdot f_c + 1.00 \quad \text{for } 2 \text{ kN} \leq P \leq 25 \text{ kN}$$

$$P = 0.80 \cdot f_c + 5.00 \quad \text{for } 25 \text{ kN} \leq P \leq 60 \text{ kN}$$

- 7.2 PULLOUT FORCE TO 150mm CUBE COMPRESSIVE STRENGTH  
The conversion equation between pullout force P in kN and 150mm cube compressive strength  $f_c$  is recommended as:

$$P = 0.75 \cdot f_c + 2.20 \quad \text{for } 5 \text{ kN} \leq P \leq 60 \text{ kN}$$

## 8. EVALUATION BY CONTROL IN TOTAL

### 8.1 DEFINITION

Control in total is said to be performed, when every single batch in a control section is tested. The observation is average of the pullout forces of LOK-TESTS or CAPO-TESTS made within the batch placed.

### 8.2 ACCEPTANCE CRITERION

The concrete of a placed batch is accepted if the observation is minimum 80% of the specified strength as measured on standard cylinders or cubes. A control section is only accepted if all batches are accepted accordingly.

### 8.3 WHEN TO CHOOSE CONTROL IN TOTAL

Control in total has to be chosen if the number of batches in a control section is 3 or less.

The contractor may choose control in total instead of control by sample testing as later described.

The design engineer may choose control in total in a control section where a great degree of safety is required. In this case it should be clearly stated in the specification.

## 9. EVALUATION BY CONTROL BY SAMPLE TESTING

### 9.1 DEFINITION

Control by sample testing is said to be performed when the number of batches tested is less than the number of batches placed in the control section, but larger than or equal to the number of minimum sample size as mentioned in clause 5.

The following rules are applied:

- The sample size n (number of observations) and the average  $\bar{f}_c$  of the n observations is calculated using the conversion equations in clause 7.
- From the following expression the un-documented coefficient of variation v is calculated:

$$\begin{aligned} v &= 0.22 && \text{for } 5 \leq f_c \leq 10 \text{ MPa} \\ v &= 0.23 - 0.002 \cdot f_c && \text{for } 15 \leq f_c \leq 35 \text{ MPa} \\ v &= 0.14 && \text{for } 40 \leq f_c \leq 50 \text{ MPa} \end{aligned}$$

or found from the following table:

$f_c$ (MPa)	5	10	15	20	25	30	35	40	45	50
$v$ (%)	0.22	0.22	0.20	0.19	0.18	0.17	0.16	0.14	0.14	0.14

- The factor  $k_n$  is calculated from:

$$k_n = \exp \left( \left( 2.28 + \frac{1}{\sqrt{n}} \right) \cdot v - 0.1875 \right)$$

or found from the following table:

$k_n$ factor for: $v$ (%)	n				
	3	6	9	15	30
0.06	0.98	0.97	0.97	0.97	0.96
0.08	1.04	1.03	1.02	1.02	1.01
0.10	1.10	1.08	1.08	1.07	1.06
0.12	1.17	1.14	1.13	1.12	1.11
0.14	1.24	1.21	1.20	1.18	1.17
0.15	1.27	1.24	1.23	1.21	1.20
0.16	1.31	1.27	1.26	1.24	1.23
0.18	1.39	1.34	1.33	1.31	1.29
0.20	1.47	1.42	1.40	1.38	1.36
0.20	1.55	1.50	1.47	1.45	1.43

## 9.2 ACCEPTANCE CRITERION

The control section is accepted if

$$\bar{f}_c \geq 0.8 \cdot k_n \cdot f_c$$

otherwise the section is rejected.

## 10. EVALUATION BY ALTERNATIVE CONTROL

### 10.1 DEFINITION

Alternative control is said to be performed if the testing with pullout testing is generating a yes/no-statement for the observed properties or characteristics.

Alternative control may be used if

- The pullout insert is only loaded to a certain pullforce. The observation is a "yes" if the insert is not pulled to failure, otherwise it is a "no".
- If two-sided control is needed, where the pullout forces have to be placed within a declared and accepted interval, e.g. from 40 kN to 50 kN.

### 10.2 ACCEPTANCE CRITERION BY ALTERNATIVE CONTROL

By sample testing using alternative control a yes/no statement is given for each observation. The number of no-statements in relation to the sample size decides if the section is accepted or rejected.

The decision rule appears from the following table, where the sample size has to be larger than or equal to the one assigned in clause 5.



Sample size	Max.No. of defects	Sample size	Max.No. of defects
3-12	0	65-79	6
13-19	1	80-94	7
20-29	2	95-109	8
30-39	3	110-124	9
40-49	4	125-145	10
50-64	5		

If the control section is tested by control in total, no observations are allowed to be defect.

## 11. EKSTREME VALUES

### 11.1 REASONS FOR EXTREME VALUES

The following reasons may be causing extreme pullout test values:

- To weak concrete caused by mistakes in the production or in the curing procedure
- Incorrect installed LOK-TEST or CAPO-TEST inserts
- A failure cone of the pullout test which is not acceptable
- Foreign bodies in the failure cone

Detailed instruction in the evaluation of the correctness of a pullout test is given in the instruction manual supplied with the equipment.

### 11.2 SUPPLEMENTARY TESTING

An extreme low pullout force is allowed to be excluded in the evaluation if a mistake in the testing procedure is documented. Supplementary testing with CAPO-TEST may replace such test results.

### 11.3 PETROGRAPHIC ANALYSES

If the supplementary testing with CAPO-TEST consistently indicates to low pullout forces, the reason has to be established by petrographical analyses of the concrete in question.

## 12. REPORT

The report has to contain all the informations required in Danish Standard DS 423.31 covering pullout testing, e.g. all relevant concrete information, position of observations, type of evaluation used, test equipment identification, testing institution and testing personel together with relevant standards and procedures.

APPENDIX 2

Maturity functions for Aalborg Portlands three types of cement

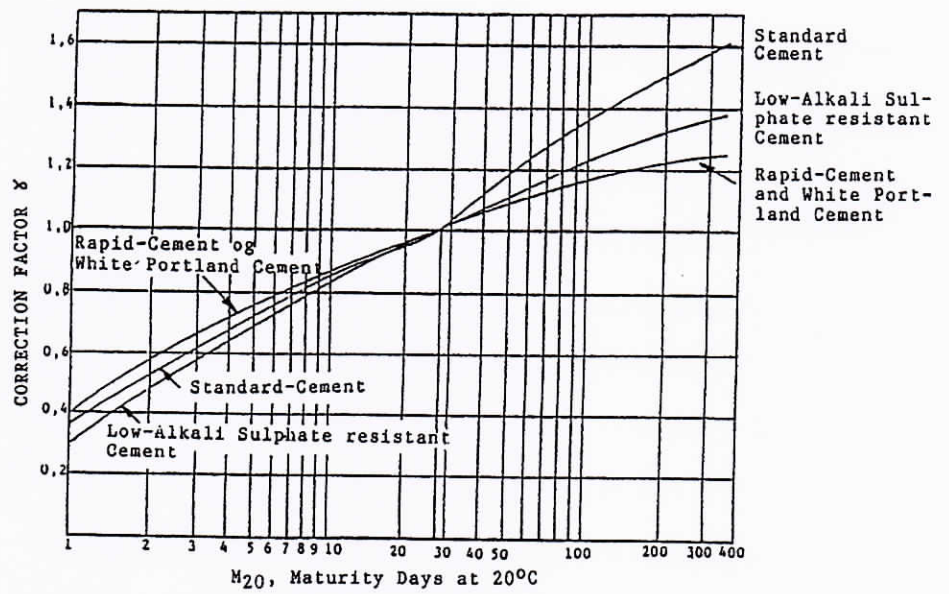

The correction factor  $\gamma$  as a function of the concrete maturity (M<sub>20</sub>, maturity days at 20°C).

Reference: Ct0, Aalborg Portland, Beton-Teknik 01/22/85 p.3